

Clamp-On Ground Resistance Tester Models 3711 & 3731



US Patent No: 362,639

Models 3711 and 3731 measure ground rod and grid resistance in any environment without the use of auxiliary ground rods. Clamp-on ground resistance testers are used on multi-grounded systems without disconnecting the ground under test. The Models 3711 and 3731 simply clamp around the ground conductor or rod and measure the resistance to ground fast and accurately.

By performing measurements on installed ground systems, the user also verifies the quality of the grounding connections and bonds.

Resistance and continuity of grounding loops around pads and buildings may also be measured.

Both models include a current measurement function. The probe's high sensitivity enables measurement of leakage current flowing to ground or circulating in ground loops down to 1mA and neutral and phase currents to 30Arms. This feature provides additional information which is vital in distribution ground networks carrying higher levels of noise and harmonics that affect power quality.

The Model 3731 offers an alarm function and a memory (logging) function. In the alarm mode, the probe will audibly and visually indicate readings beyond set point. The user may also have the alarm initiated above or below the set point. This alarm feature permits quick field checks where only "pass" or "fail" readings will suffice.

Features

- Simple and fast clamp-on operation – no leads, no auxiliary rods or spacing requirements
- Direct reading of ground resistance from 0.01Ω to 1200Ω
- Direct reading of continuity and ground loop resistance
- Direct reading of ground leakage or phase current from 1mA to 30Arms
- Jaw design with large 1.25" (32mm) window – accommodates up to 1000MCM cables
- Auto-Off for power management
- Alarm function with adjustable set point and buzzer for quick field checks (Model 3731)
- Memory function to store 99 field measurements for later retrieval and analysis (Model 3731)
- Meets EN 61010, Cat. III
- CE Mark and UL approved
- Rugged Lexan® head and body construction resists breakage
- Alarm settings and stored memory information saved during shutdown (Model 3731)
- Patented design

Applications

- Measure electrical ground rod and grid resistance
- Use on multi-grounded systems without disconnecting the ground rod under test
- Measure resistance and continuity of grounding loops around pads and buildings
- Measure leakage current flowing to ground or circulating in ground systems
- Conduct field surveys and retrieve and analyze readings at a later time
- Use on cell towers and telecommunication sites
- Use on pools, spas and other consumer installations



Product Construction

The Models 3711 and 3731 bodies are built of Lexan® (or equivalent polycarbonate) for rugged use. The probe heads are encapsulated in a double-walled shell for extra strength and reinforced for enhanced field reliability. Overall construction and mechanical design ratings such as drop test, shock, vibration and weatherproofing against water penetration or dust, meet or exceed IEC standards. The products have been designed to EN 61010, Cat. III and UL approved. Both models are CE Marked.

The probe head, (jaw) is a key component in the measurement and overall product performance. The large jaw thickness permits use on tight ground conductors on poles and in manholes. The 1.25" (32mm) opening accommodates not only ground rods, but also larger ground conductors (up to 1000MCM) typically found in telecommunication buildings or railroad applications.

The inner jaw is composed of two independent and individually shielded magnetic cores, permitting measurement without noise interference or cross talk common to separate probe instruments.

Thorough mechanical design, including small winglets, ensures reliable and repetitive jaw alignment for accuracy and prevents undesirable contamination into the jaw spring assembly.

CE requirements and design minimize electromagnetic interference near substations and tower sites.

The ergonomic body design permits one-handed operation. The guard provides additional strength and prevents the hand from slipping or coming into contact with conductors under test. The LCD lens cover may be easily replaced if scratched. The sealed push-buttons directly access all test functions and are easily operated even with gloved hands.

Overview of Functions



- Ω Displayed when measuring resistance
- mA, A** Displayed when measuring current
- 100% Percentage of battery life remaining
- Flashing indicates low battery condition
- Indicates the Auto-Off feature is inactive
- Indicates Alarm Active Hi or Lo depending on which arrow is displayed
- HOLD** HOLD pushbutton has been pressed
- Active beeper function
- NOISE** Noise in the reading
- Probe jaws not closed properly.
- Alarm set points
- MEM** Memory function active
- MR 88** Memory Recall (MR) and location (from 1 to 99)
- R < 1Ω** Resistance measured is below 1Ω

Functions & Features

Model	3711	3731
Ohms Range	✓	✓
Arms Range	✓	✓
Hold Function	✓	✓
Self Test	✓	✓
Auto-Off	✓	✓
Battery Life Indicator	✓	✓
Noise Indicator	✓	✓
Open Jaw Indicator	✓	✓
Closed Loop Indicator	✓	✓
Multi-Tone Beeper	✓	✓
Alarm Function	-	✓
Memory (Logging)	-	✓



Buttons

ON/OFF: Power ON or power OFF. Activates display self test at power-up

Ω: Resistance measurement. (Increment the alarm set point and the memory position when in programming mode.)

A: Current measurement. (Adjusts the alarm set point and the memory position when in programming mode.)

AL (3731 only): Activate/deactivate the alarm function. Access the value of the alarm set point when in programming mode

MEM (3731 only): Activate the memory function or to read the stored values in MR (Memory Recall). Clears the memory when in programming mode

Specifications

ELECTRICAL							
Ground Resistance Ranges	Auto-Ranging 0.01Ω to 1200Ω						
Range	0.10 to 1.00Ω	1.0 to 50.0Ω	50.0 to 100.0Ω	100 to 200Ω	200 to 400Ω	400 to 600Ω	600 to 1200Ω
Resolution	0.01Ω	0.1Ω	0.5Ω	1Ω	5Ω	10Ω	50Ω
Accuracy	±2% of Reading ± 0.02Ω	±1.5% of Reading ± 0.1Ω	±2% of Reading ± 0.5Ω	±3% of Reading ± 1Ω	±6% of Reading ± 10Ω	±10% of Reading ± 10Ω	Approx. 25% of Reading ± 50Ω
Current Measurement Ranges	Auto-Ranging 1mA to 30.00Arms						
Range	1 to 299mA		0.300 to 2.999A		3.00 to 29.99A		
Resolution	1mA		0.001A		0.01A		
Accuracy	±2.5% of Reading + 2mA		±2.5% of Reading + 2mA		±2.5% of Reading + 20mA		
Resistance Measurement Frequency	2403Hz						
Resistance Overload	OL displayed above 1200Ω						
Current Measurement Frequency	47 to 800Hz						
Current Overload	OL displayed above 29.99Arms						
Power Source	9V Alkaline battery (IEC 6LF22 or NEDA 1604A)						
Battery Life	Typical: 8 hours or approx. 1000 measurements of 30 seconds						
MECHANICAL							
Display	3 ³ / ₄ Digit, 1.73 x 1.10" (44 x 28mm)						
Operating Temperature	14° to 131°F (-10° to 55°C)						
Storage Temperature	-22° to 158°F (-30° to 70°C)						
Relative Humidity	10 to 90% RH @ 14° to 104°F (-10° to 40°C), 75% RH @ 131°F (55°C)						
Dimensions	9.25 x 3.94 x 2.17" (235 x 100 x 55mm)						
Weight	2.2 lbs (1kg)						
Jaw Window Diameter	1.25" (32mm)						
Jaw Opening	1.38" (35mm)						
Case	Lexan® 920A or equivalent (UL94V2)						
Colors	Gray body, red jaws						
Shock Test	IEC 68-2-27						
Vibration Test	IEC 68-2-6						
Drop Test (1m)	IEC 68-2-32						
Dielectric Test	2500V _{AC}						
Environmental	IP30, IEC 359, Group III						
Working Voltage	150V, Cat. III – Pollution Degree 2; 300V, Cat. II – Pollution Degree 2						
Max Overload (A or Ω Function)	100A continuous, 200A (<5s) 50/60Hz						
U.S. Patent	No. 362,639						
UL File No.	E192383						
SAFETY							
Safety Rating	EN 61010-2-032 (Class 2) Double Insulation						
CE Mark	Yes						

Accessories



*Clamp-on Ground Resistance Tester
Models 3711 & 3731 include
calibration loop, battery and user manual
in hard carrying case.*

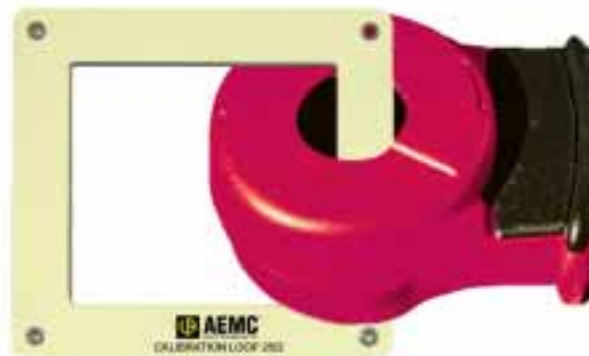

Calibration Check Loop (included)

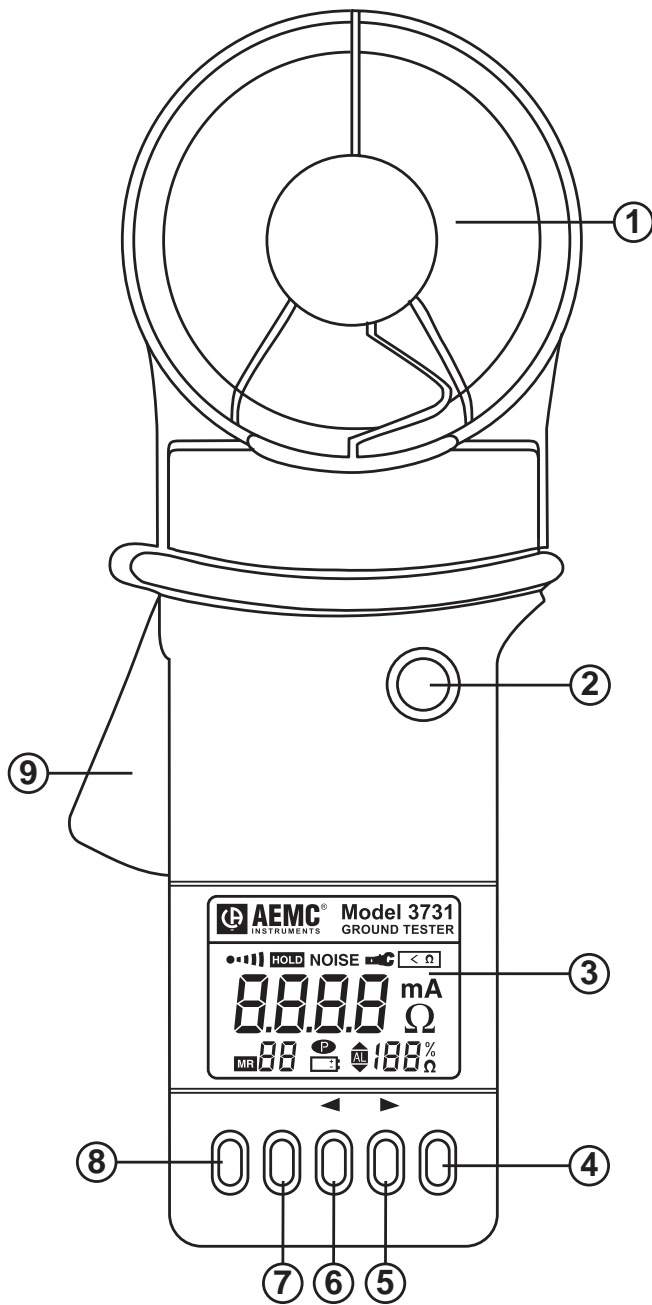

- 1. Head assembly
- 2. Hold button
- 3. Display
- 4. On/Off
- 5. Ω: Resistance measurements
- 6. A: Current measurements
- 7. AL: Alarm button (Model 3731 only)
- 8. MEM: Memory button (Model 3731 only)
- 9. Lever opens and closes jaws

ORDERING INFORMATION

CATALOG NO.

Ground Resistance Tester Model 3711 (Clamp-On)	Cat. #2117.60
Includes hard carrying case, 9V Alkaline battery, 25Ω calibration check loop and user manual	
Ground Resistance Tester Model 3731 (Clamp-On) with memory and alarm	Cat. #2117.61
Includes hard carrying case, 9V Alkaline battery, 25Ω calibration check loop and user manual	

Contact Us

Worldwide

Optimum Energy Products Ltd.
333, 11979 - 40th Steet S.E.
Calgary, Alberta Canada T2Z 4M3
Toll Free (877) 766-5412
(403) 256- 3636 • Fax (403)256-3431
www.optimumenergy.com www.groundtesterstore.com